

SC-ST-Adaptor

Features

- Central mount or flange mount
- HBK1 and HBK2 with washer and nut
- HBK3 and HBK4 with 2 bolts M2x6
- Extreme mechanical stability

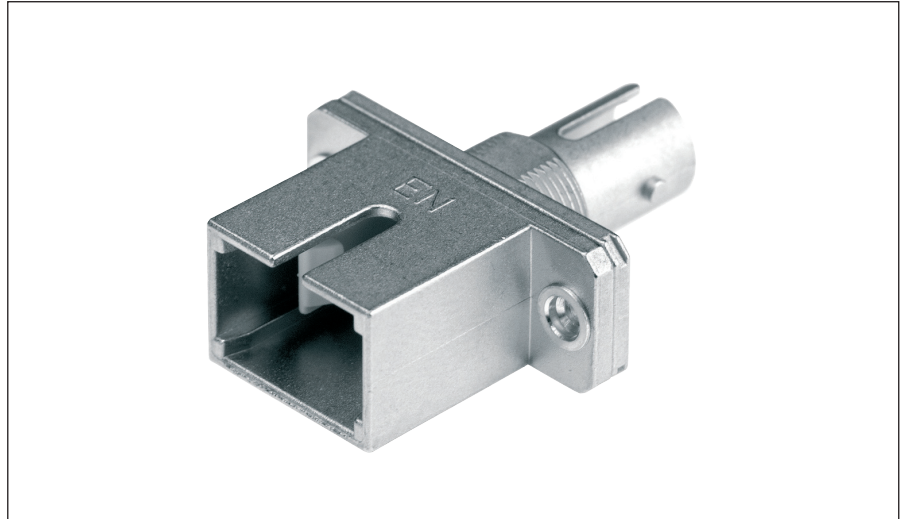

Dimensions

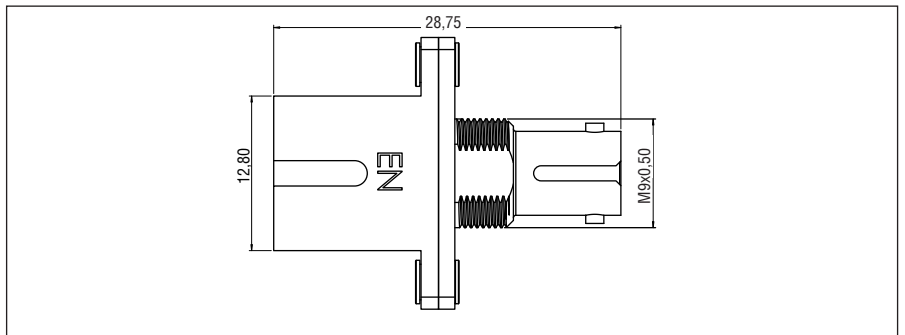
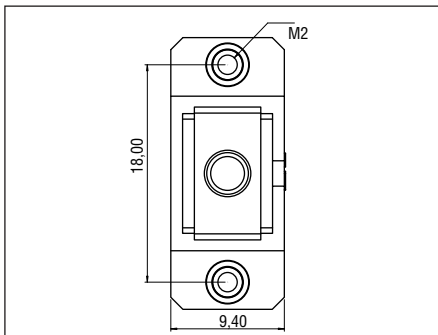

Technical Data

Part number	HBK1-SCST-M25M HBK3	HBK1-SCST-K25M HBK3	HBK2-SCST-K25S HBK4
Description	Multimode	Multimode	Singlemode
Typical loss	≤ 0.2 dB	≤ 0.15 dB	≤ 0.1 dB
Housing material / colour of interior	metal / beige	metal / beige	metal / blue
Mating cycles	500	2.000	2.000
Material sleeve	phosphor-bronze, split	ZrO ₂ , split	ZrO ₂ , split
Operating temperature	-40 °C – +85 °C		
Storage temperature	-40 °C – +90 °C		
Fixing	M9x0.5 or 2-hole-flange		

HBK1 = Multimode with washer and nut

HBK2 = Singlemode with washer and nut

HBK3 = Multimode with 2 bolts M2x6

HBK4 = Singlemode with 2 bolts M2x6