

ST-Connector with metal ferrule for special cables

Features

- One connector for different cables/fibers (EUROMICRON connector concept)
- 2.5 mm ferrule, axial spring loaded
- Bayonet twist secured

Use

- Industry
- Equipment technology



Dimensions

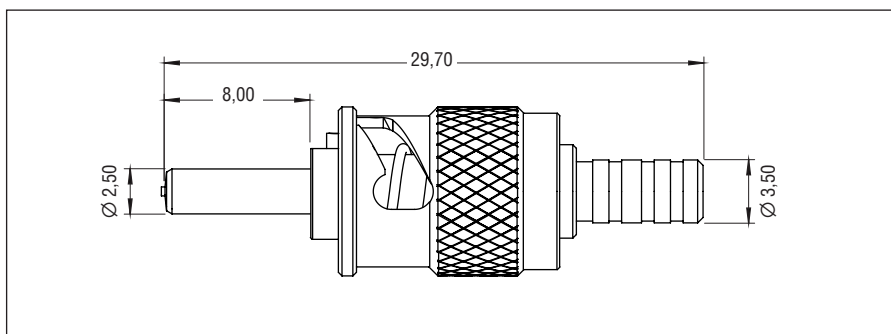

Technical Data

Part number	BST1-Mxxx*-035M
Description	Multimode
Housing material / colour	Metal / nickel-plated brass
Typical loss IL/RL	depends on hole \varnothing , cable and termination
Ferrule hole \varnothing	50 – 1000 μm (other diameter upon request)
Ferrule material	Arcap AP1D
Ferrule surface	flat after polishing
Mating cycles	500
Operating temperature	-40 °C – +85 °C
Storage temperature	-40 °C – +90 °C
Cable \varnothing	0.9 mm – 3.5 mm
Cable retention**	≥ 150 N
Notes: * Hole diameter ** Depends on cable	

Stripping length metal-ferrule

