

FSMA Connector with metal ferrule for special cables

Features

- Box nut with hexagonal / knurl
- Connector with defined air gap

Use

- Industry
- Equipment technology
- Sensor technology

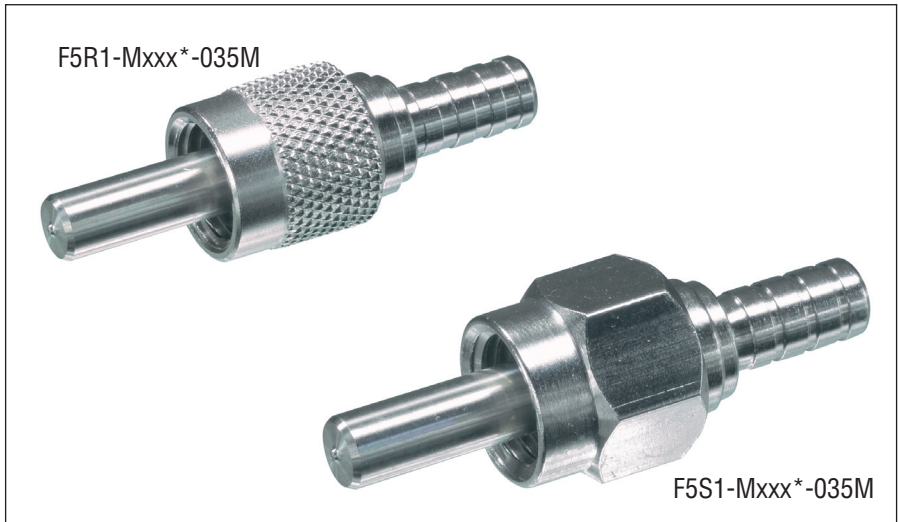

Dimensions

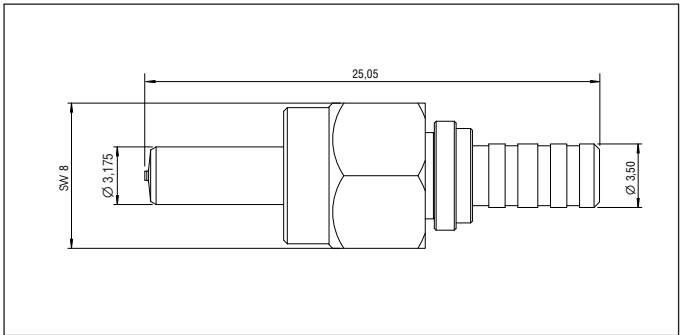
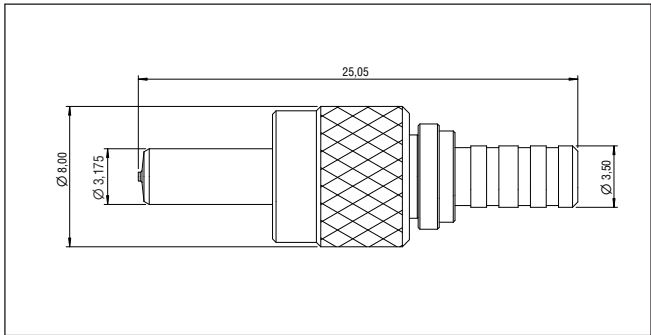

Technical Data

Part number	F5R1-Mxxx*-035M	F5S1-Mxxx*-035M
Description	Multimode	
Housing material / knurl	metal / left-right knurl	metal / hexagonal
Typical loss IL/RL	depends on hole Ø, cable and termination	
Ferrule hole Ø	50 – 1000 µm (other diameter upon request)	
Ferrule material	Arcap AP1D	
Ferrule surface	flat after polishing	
Mating cycles	500	
Operating temperature	-40 °C – +85 °C	
Storage temperature	-40 °C – +90 °C	
Cable Ø	0.9 mm – 3.5 mm	
Cable retention**	≥ 150 N	
Notes: * Hole diameter ** Depends on cable		

Stripping length metal-ferrule

