

FSMA 905-Connector with knurl

Features

- Screw cap with knurl
- Connector with defined air gap

Use

- Predominantly for industrial networks



Dimensions

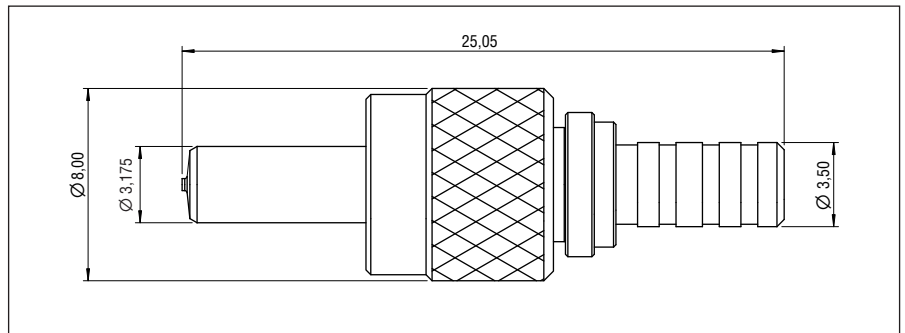

Technical Data

Part number	F5R1-M128-035M	F5R1-K128-035M	F5R2-K127-035S
Description	Multimode	Multimode	Singlemode
Housing material / knurl	metal / left-right knurl		metal / knurl axially parallel
Typical loss* IL	≤ 0.25 dB	≤ 0.2 dB	≤ 0.15 dB
Ferrule hole Ø	128 µm	128 µm	127 µm
Ferrule material	Arcap AP1D	ZrO ₂	ZrO ₂
Ferrule surface	flat after polishing		
Mating cycles	500	1.000	1.000
Operating temperature	-40 °C – +85 °C		
Storage temperature	-40 °C – +90 °C		
Cable Ø	0.9 mm – 3.5 mm		
Cable retention **	≥ 150 N		

Notes: * Loss depends on termination and fiber ** Depends on cable

Stripping length metal-ferrule

